

EMICON

INNOVATION AS ENERGY



AN ENEX TECHNOLOGIES COMPANY

PWE Kp

INDOOR MONOBLOCK HEAT PUMPS
WATER CONDENSED
EQUIPPED WITH SCROLL COMPRESSORS
(CYCLE INVERSION ON USER SIDE)



INSTALLATION, USE AND MAINTENANCE TECHNICAL MANUAL

Incorporated in this document are the following:

- Declaration of conformity
- Technical manual
- Dimensional drawing



RETAIN FOR FUTURE REFERENCE



Multiple instructions:
Consult the specific part



Read and understand
the instructions before
undertaking any work on
the unit

Reproduction, data storage and transmission, even partial, of this publication, in any form, without the prior written authorisation of the Company, is prohibited. The Company can be contacted for all inquiries regarding the use of its products.

The Company follows a policy of continuous product development and improvement and reserves the right to modify specifications, equipment and instructions regarding use and maintenance at any time, without notice.

Declaration of conformity

We declare under our own responsibility that the below equipment complies in all parts with the CEE and EN directives.

The declaration of conformity is enclosed to the technical booklet enclosed with the unit.

INDEX

1. INTRODUCTION	5
1.1 Preliminary information	5
1.2 Aim and content of the manual	5
1.3 How to store this manual	5
1.4 Manual updates	5
1.5 How to use this manual	5
1.6 Potential risks	6
1.7 General description of symbols used	7
1.8 Safety symbols used	8
1.9 Limitations and prohibited use	8
1.10 Unit identification	9
2. SAFETY	10
2.1 Warning on potentially dangerous toxic substances	10
2.2 Refrigerant handling	12
2.3 Prevention of inhalation of high vapor concentrations	12
2.4 Procedures in the event of accidental release of refrigerant	12
2.5 Main Toxicological information on the type of refrigerant used	12
2.6 First aid measures	12
3. TECHNICAL CHARACTERISTICS	13
3.1 Unit description	13
3.2 Technical data	15
3.3 Operation limits	16
3.4 Correction tables	17
4. INSTALLATION	18
4.1 General safety guidelines and use of symbols	18
4.2 Workers' health and safety	18
4.3 Personal protective equipment	18
4.4 Inspection	19
4.5 Transport and handling	19
4.6 Storage	20
4.7 Unpacking	20
4.8 Lifting and handling	20
4.9 Location and minimum technical clearances	21
4.10 Hydraulic connections	22
4.11 Chemical characteristics of the water	24
4.12 User circuit minimum water content	25
4.13 Filling the hydraulic circuit	25
4.14 Emptying the installation	25
4.15 Electric connections: preliminary safety information	26
4.16 Electric data	27
5. UNIT START UP	28
5.1 Preliminary Checks	28
5.2 Description of the control panel	31
5.3 Remote control panel	32
6. USE	34
6.1 Switch the unit on	34
6.2 Stop	35
6.3 Stand-by	35
6.4 How to change set points	35
6.5 Parameters list	36
6.6 Acoustic signal silencing	36
6.7 Alarm reset	36
6.8 Display alarm history	37
7. UNIT MAINTENANCE	37
7.1 General warnings	37

7.2 Drive access	38
7.3 Routine maintenance.....	38
7.4 Periodical checks.....	39
7.5 Refrigerant circuit repair	42
8. DECOMMISSIONING.....	43
8.1 Unit Isolation & drain down	43
8.2 Disposal, recovery and recycling	43
8.3 RAEE directive (only for EC countries).....	43
9. DIAGNOSIS & TROUBLESHOOTING	44
9.1 Fault finding	44
10. DIMENSIONAL DRAWINGS	45

1. INTRODUCTION

1.1 Preliminary information

Reproduction, storage or transmission of any part of this publication in any form, without the prior written consent of the Company, is prohibited.

The unit to which these instructions refer, is designed to be used for the the purposes described and to be operated in accordance with these instructions.

The Company will not be liable for claims for damage caused to persons, animals, material goods or property caused by improper installation, adjustment and maintenance or improper use. Any use not specified in this manual is prohibited.

This document is intended to provide information only and does not form a contract with third parties.

The Company pursues a policy of constant improvement and development of its products and therefore reserves the right to change the specifications and the documentation at any time, without notice and without obligation to update existing equipment.

1.2 Aim and content of the manual

These instructions are intended to provide the information required for the selection, installation, use and maintenance of the unit.

They have been prepared in accordance with the European Union laws and with the technical standards in force at the date of issue of the instructions.

The instructions contain all the necessary information to prevent any reasonably foreseeable misuse.

1.3 How to store this manual

The manual must be kept in a suitable place with easy access for users and operators, protected from dust and damp.

The manual must always accompany the unit during the entire life cycle of the same and therefore must be transferred to any subsequent user.

1.4 Manual Update

It is recommended that the manual is updated to the latest revision available.

If updates are sent to the customer they must be added to this manual.

The latest information regarding the use of its products is available by contacting the Company.

1.5 How to use this manual



The manual is an integral part of the unit.



Users or operators must consult the manual before performing any operation and especially so when transporting, handling, installing, maintaining, or dismantling the unit in order to eliminate uncertainty and reduce risk.

In these instructions symbols have been used (described in the following paragraphs) to draw the attention of operators and users to the operations that have a higher risk and which must be performed safely.

1.6 Potential Risks

Whilst the unit has been designed to minimize any risk posed to the safety of people who will interact with it, it has not been technically possible to eliminate completely the causes of risk. It is therefore necessary to refer to the requirements and symbolism below:

LOCATION OF RISK	POTENTIAL RISK	METHOD OF INJURY	PRECAUTIONS
Thermal heat exchangers.	Small stab wounds.	Contact	Avoid any contact, use protective gloves.
Fan and fan grilles.	Cuts, eye damage, broken bones.	Insertion of sharp objects through the grid while the fans are operating.	Never put objects through the protection grilles.
Internal component: compressors and discharge pipes	Burns.	Contact	Avoid any contact, use protective gloves.
Internal component: electric cables and metallic parts	Electrocution, severe burns.	Defect in the supply cable insulation, live metallic parts.	Adequate protection of power cables, ensure correct earthing of all metal parts.
External to unit: unit enclosure	Poisoning, severe burns.	Fire due to short circuit or overheating of the supply cable external to unit.	Size cables and mains protection system in accordance with iee regulations.
Low pressure safety valve.	Poisoning, severe burns.	High evaporating pressure causing a refrigerant discharge during maintenance.	Carefully check the evaporating pressure during the maintenance operations.
High pressure safety valve.	Poisoning, severe burns, hearing loss.	Activation of the high pressure safety valve with the refrigerant circuit open.	If possible, do not open the refrigerant circuit valve; carefully check the condensing pressure; use all the personal protective equipment required by law.
Entire unit	External fire	Fire due to natural disasters or combustions of elements nearby unit	Provide the necessary fire-fighting equipment
Entire unit	Explosion, injuries, burns, poisoning, folgoramento for natural disasters or earthquake.	Breakages, failures due to natural disasters or earthquake	Plan the necessary precautions both electrical (suitable differential magneto and electrical protection of the supply lines; greatest care during the connections of the metal parts), and mechanical (special anchors or seismic vibrations to prevent breakages or accidental falls).

1.7 General Description of Symbols Used

Safety symbols combined in accordance with ISO 3864-2:



BANNED

A black symbol inside a red circle with a red diagonal indicates an action that should not be performed.



WARNING

A black graphic symbol added to a yellow triangle with black edges indicates danger.



ACTION REQUIRED

A white symbol inserted in a blue circle indicates an action that must be done to avoid a risk.

Safety symbols combined in accordance with ISO 3864-2:



The graphic symbol "warning" is qualified with additional safety information (text or other symbols).

1.8 Safety symbols used



GENERAL RISK

Observe all signs placed next to the pictogram. The failure to follow directions may create a risk situation that may be injurious to the user.



ELECTRICAL HAZARD

Observe all signs placed next to the pictogram.

The symbol indicates components of the unit and actions described in this manual that could create an electrical hazard.



MOVING PARTS

The symbol indicates those moving parts of the unit that could create risk.



HOT SURFACES

The symbol indicates those components with high surface temperature that could create risks.



SHARP SURFACES

The symbol indicates components or parts that could cause stab wounds.



EARTH CONNECTION

The symbol identifies Earthing connection points in the unit.



READ AND UNDERSTAND THE INSTRUCTIONS

Read and understand the instructions of the machine before any operations.



RECOVER OR RECYCLE MATERIAL

1.9 Limitations and prohibited use

The machine is designed and built exclusively for the uses described in "Limitations of use" of the technical manual. Any other use is prohibited because it may pose a potential risk to the health of operators and users.



The unit is not suitable for operations in environments:

- excessively dusty or potentially explosive atmospheres;
- where there are vibrations;
- where there are electromagnetic fields;
- where there are aggressive atmospheres

1.10 Unit identification

Each unit has a rating plate that provides key information regarding the machine. The rating plate may differ from the one shown below as the example is for a standard unit without accessories. For all electrical information not provided on the label, refer to the wiring diagram. A facsimile of the label is shown below:

TEL. +39 0543495611 FAX +39 0543 495612 Via A.Volta 49 Meldola FC ITALY		NB 0948							
MODELLO MODEL ModÈLE MODEL		ANNO DI COSTRUZIONE / PED CATEGORY MANUFACTURE YEAR / PED CATEGORY JAHR VON KONSTRUKT / PED KATEGORIE ANNÈ DE FABBRICAT / CATÈGORIE PED	2019 CAT						
MATRICOLA SERIAL NR N° DE SÈRIE STAMM NR		CORRENTE MAX. MAX CURRENT INPUT MAXIMALEN STROM AMPÈRES MAXIMALE	A						
ALIMENTAZIONE ELET. SUPPLY VOLTAGE ALIMENTATION ELECT. SPANNUNG	400 V +/- 10% - 50 Hz +/- 2% - 3 PH - N - GND	ASSORBIMENTO ELETTRICO NOMINALE PUISSANCE ÈLECTRIQUE NOMINALE NOMINAL ABSORBED POWER NOMINALELEISTUNGSANNAHME	kW						
GAS REFRIGERANTE REFRIGERANT RÈFRIGÈRANT KALTEMITTEL	R290 / 3,3	CORRENTE CORTO CIRCUITO SHORT CIRCUIT CURRENT COURANT COURT-CIRCUIT STROM KURZSCHLUSS	kA 10						
CARICA REFRIGERANTE REFRIGERANT CHARGE KALTEMITTEL CHARGE FRIGORIGÈNE	<table border="1"> <tr> <td>C1</td> <td>C2</td> <td>kg.</td> </tr> <tr> <td>C1</td> <td>C2</td> <td>CO2 Ton</td> </tr> </table>	C1	C2	kg.	C1	C2	CO2 Ton	PESO OPERATIVO OPERATING WEIGHT POIDS OPERATION. ARBEITSGEWICHT	kg.
C1	C2	kg.							
C1	C2	CO2 Ton							
LATO BASSA PRESSIONE / LOW PRESSURE SIDE CIRCUIT BASSE PRESSION / NIEDERDRUCKSEITE		LATO ALTA PRESSIONE / HIGH PRESSURE SIDE CIRCUIT HAUTE PRESSION / HOCHDRUCKSEITE							
PRESSIONE DI PROGETTO DESING PRESSURE PRESSION DE PROJET DRUCK DES PROJEKTES	-- Bar	PRESSIONE DI PROGETTO PS DESING PRESSURE PS PRESSION DE PROJET PS DRUCK DES PROJEKTES PS	-- Bar						
TEMP. MIN PROGETTO MINI DESING TEMPERATURE KLEINSTE TEMP. DES PROJEKTES TEMP. MOINORE DE PROJET	- 30 °C	TEMP. MIN PROGETTO MINI DESING TEMPERATURE KLEINSTE TEMP. DES PROJEKTES TEMP. MOINORE DE PROJET	- 10 °C						
MAX TEMPERATURA PROGETTO MAX DESING TEMPERATURE MAXIMALE TEMP. DES PROJEKTES MAXIMUM TEMP DE PROJET	+ 54 °C	MAX TEMPERATURA PROGETTO MAX DESING TEMPERATURE MAXIMALE TEMP. DES PROJEKTES MAXIMUM TEMP DE PROJET	+110 GAS °C + 65 LIQU						
TARATURA ORGANO SICUREZZA SETTING OF SAFETY DEVISE MISE AU POINT DISPOSITIF DE SECURITÈ EINSTELLWERT ICHERHEITSELEMENT		-- Bar							



The product label should never be removed from the unit.

2. SAFETY

2.1 Warning on potentially dangerous toxic substances

2.1.1 Identification of the used fluid: R290 (Propane)

WARNING!

The refrigerante R290 (PROPANE) is flammable and it must be handled only by competent and responsible operators, under the conditions specified in the safety regulations in force.



DO NOT SMOKE

NO NAKED FLAMES





The refrigerant used is Propane (R290). In compliance with 2014/68/EU directive (hereafter: PED), this substance is considered a gas (PED, art. 13) of Group 1 which contains the dangerous fluids (extremely flammable). According EN 378-1, att. F, Propane is classified as a Group 3 substance (low toxicity, high flammability).

Safety information of this refrigerant are listed in the following table

Chemical name	Propane
Designation (ISO 817)	R290
Chemical formula	C_3H_8
Safety group (EN378-1)	A3
PED classification	Group 1 Gas
Lower flammability limit (LFL)	0,038 kg/m ³ – 2,1% m ³ /m ³ ()
Upper flammability limit (UFL)	0,177 kg/m ³ – 9,8% m ³ /m ³ (1)
Vapour density (at 25°C, 101.3 kPa)	1,832 kg/m ³
Relative density	1,56
Molecular mass	44 kg/kmol
Normal boiling point	-42°C
Self-ignition temperature	470°C
Flammability temperature	-104°C
Ozone Depletion Potential (ODP)	0
Global Warming Potential (GWP - 100-year time horizon)	3 (CO ₂ = 1)

Note that Propane has a higher density than the air one, therefore in case of leaks, it will tend to flow down

CHEMICAL COMPOSITION OF PROPAN USED AS A REFRIGERANT:

Refrigerant content $\geq 99,5\%$ by mass
 Organic impurities $\leq 0,5\%$ by mass

1,3 Butadiene (for each single unsaturated multiple hydrocarbon)	≤ 5 ppm in mass
Normal Hexane	≤ 50 ppm in mass
Benzene (for each aromatic mixture)	≤ 1 ppm in mass
Sulfur	≤ 2 ppm in mass
Non-condensable gases	$\leq 1,5\%$ in volume della fase vapore
Water	≤ 25 ppm in mass
Acid content	$\leq 0,02$ mg KOH/g per la neutralizzazione
Evaporation residue	≤ 50 ppm in mass
Particles / solids	Nessuno (ispezione visiva)
Evaporating temperature glide	$\leq 0,5$ K
Practical limit (EN378-1, all.F)	$0,008$ kg/m ³
Acute Toxicity Exposure Limit (ATEL) / O ₂ Deprivation Limit	$0,09$ kg/m ³

Propane highlights compatibility problems with some rubber or plastic types, particularly if chlorinated. Tests on critical materials will be required.

2.1.2 Identification of the Type of Oil Used.

The lubricant used is polyester oil. Please refer to the information provided on the compressor data plate.



For further information regarding the characteristics of the refrigerant and oil used, refer to the safety data sheets available from the refrigerant and oil manufacturers and attached in this manual.

Main Ecological Information Regarding the Types of refrigerants Fluids used.



ENVIRONMENTAL PROTECTION : Read the ecological information and the following instructions carefully.

2.1.3 Effects of discharges

Discharges into the atmosphere of this product does not cause a long-term contamination.

2.1.4 Exposure controls and personal protection

Wear protective clothing and gloves, protect your eyes and face

2.1.5 Professional exposure limits

Limit values TLV-TWA: 2500 ppm

2.2 Refrigerant handling



Users and maintenance personnel must be adequately informed about the possible risks of handling potentially toxic substances. Failure to follow such instructions can cause damage to personnel or to the unit.

2.3 Prevent inhalation of high vapor concentration

Atmospheric concentrations of refrigerant must be minimized and kept to a level that is below the occupational exposure limit. Vapor is heavier than air and can form dangerous concentrations near the ground where the ventilation rate is lower. Always ensure adequate ventilation. Avoid contact with open flames and hot surfaces as this can cause toxic and irritating decomposition products to form. Avoid contact between liquid refrigerant and the eyes or skin.

2.4 Procedures to be adopted in the event of accidental release of refrigerant

Ensure suitable personal protection (especially respiratory protection) during cleaning operations.

If deemed safe, isolate the source of the leak. If the leakage is small and if adequate ventilation is provided, allow the refrigerant to evaporate. If the loss is substantial ensure that measures are taken to adequately ventilate the area.

Contain spilled material with sand, earth or other suitable absorbent material.

Do not allow the refrigerant to enter drains, sewers or basements, as pockets of vapor can form.

2.5 Main Toxicological Information Regarding the Type of refrigerant used

2.5.1 Inhalation

A high atmospheric concentration can cause anaesthetic effects with possible loss of consciousness. Prolonged exposure may lead to irregular heartbeat and cause sudden death. Higher concentrations may cause asphyxia due to the reduced oxygen content in the atmosphere.

2.5.2 Contact with skin

Splashes of nebulous liquid can produce frostbite. Probably not hazardous if absorbed through the skin. Repeated or prolonged contact may remove the skin's natural oils, with consequent dryness, cracking and dermatitis.

2.5.3 Contact with eyes

Splashes of liquid may cause frostbite.

2.5.4 Ingestion

While highly improbable, may produce frostbite.

2.6 First Aid Measures



Adhere scrupulously to the warnings and first aid procedures indicated in the REFRIGERANT AND LUBRICANT OIL SAFETY DATA SHEET downloadable via the following QR codes.



R290



OIL

3. TECHNICAL CHARACTERISTICS

3.1 Unit description

The packaged air cooled heatpumps of PWE Kp series are suitable for indoor installation and can be used for heating liquid solutions in systems where it is necessary to grant excellent performances and a very low environmental impact.

The units, available in 1 or 2 compressor versions on a single circuit, are designed for internal installation, in compliance with the European standard EN 378 and his updates; unit to install inside of engine rooms responding to safety regulations.

All the units are completely factory assembled, tested and supplied with refrigerant and non-freezing oil charge; so, once on installation site, they only need to be positioned and connected to the hydraulic and power supply lines. If the ATEX forced draining fan is supplied as a kit, installation and electrical connection is the installer's obligation and responsibility, following the instructions in the wiring diagram supplied with the unit.

3.1.1 Frame

Strong and compact frame, made of bended and RAL 7035 colored steel profiles, supporting all the main components, installed at sight. The technical section which contains compressors and all the cooling circuit elements is closed in a cabinet; if a refrigerant leak occurs the technician vane is automatically airy using an external ATEX fan which is able to clean all the air inside the cabinet 4 time/minute. This fan can be supplied in kit, its installation and its correct functioning is not the responsibility of the unit manufacturer.

3.1.2 Compressors

Operating on one single circuit in singol or tandem version. The compressors are installed on rubber isolation dampers, provided with direct-start motors cooled by suction gas and fitted with both overload protection and crankcase heaters. They are charged with polyester oil and the terminal board is IP54. The on-board microprocessor automatically controls the individual compressors to regulate the cooling capacity.

3.1.3 Plate exchanger

Of weld-brazed plate type, in AISI 316 stainless steel, with pipes and patented manifold so to reach a high heat exchange coefficient, 1 circuits. Its design allows a uniform water distribution, compatibly with pressure drops.

The exchanger is provided with large thickness close-cell insulating material. Max working pressure is 10 bar for water side.

3.1.4 Regenerative exchanger

Heat regenerative exchanger gas/fluid of plates type, installed on each circuit to grant a suitable overheating value to the compressor sucked gas and at the same time to increase the cooling circuit efficiency thanks to higher sub-cooling of condensing coil leaving fluid.

Insulated thermally using a close cells mattress of great thickness.

3.1.5 Cooling circuit

Composed of mechanical thermostatic expansion valve, dehydrating filter, safety valve on high pressure side, high and low pressure switches. All the units are equipped with a leak sensor which is able to turn off the compressors and turn on the extraction fan in case of a refrigerant leak occurs.

3.1.6 Electrical board

Built in compliance with 61439-1 standards, inside of which all the control system elements and the ones required for electrical motors starting and protection are located, all the components are factory connected and testes. The electrical cabinet has got a watertight structure, equipped with cable glands with protection factor of IP65/66. Besides the electrical cabinet contains all the power and control devices, microprocessor electronic board complete with keyboard and display for visualizing several function available, main switch of lock-door type, isolation transformer for auxiliary circuits, automatic switches, fuses and protection switches for compressors and fans motors, terminals for general alarm and unit remote ON/OFF, spring type terminal board and the possibility to interface to BMS system.

3.1.7 Microprocessor

Electronic unit management Microprocessor easily accessible, equipped with compressor hour counter and display installed on the external panel.

3.1.8 Safety gas sensor

At unit start, there is the heating/initializing of the sensor (about 1' duration).

During this period the internal sensor LEDs flash, the refrigerant leakage alarm is signaled, with relevant light alarm on the electrical panel, the 24Vac auxiliary circuit is not powered and the compressor cabinet forced ventilation, made through the washing fans, is activated.

After that, no further signals arrive from the sensor, the control PLC is powered ON and the unit is ready to work.

Without refrigerant leakage alarm, the forced ventilation is cyclically made, 2' per hour, but a different timing can be set through a timer.

With refrigerant leakages, the sensor activates and the leakages signaling led immediately lights, powering the control PLC OFF, and

activating the compressors cabinet washing fan. The ventilation keeps ON as long as the leakage sensor signals refrigerant presence.

The sensor has got 2 different alarm levels:

- The first one set at 20% of the LOWER FLAMMABLE LIMIT (LFL) with automatic reset; when the alarm is solved, the extraction fan stops, the PLC is again powered to return to the normal operation;
- The second one set at 30% of the LFL with manual reset; in this case, the extraction fan and the signal led will remain active and the PLC not powered till the alarm will be manually reset (disconnecting the sensor power supply or pressing the reset key inside the sensor itself).

Note: The red lamping signal on the door of the electrical panel indicates the refrigerant leakage and also the washing fan thermal alarm (to be manual reset inside the electrical cabinet), in this case the washing fan will stop, the forced ventilation is done anymore and the unit is stopped (POWER OFF).

Using the calibration tool it is possible to state if the sensor needs to be calibrated (see "Days left until maintenance= negative number)



The ATEX fan for cleaning the technical compartment can be supplied in a kit on request, in any case it is mandatory to include it and it is not the manufacturer's responsibility to verify its installation. The testing and maintenance of its correct operation is in no way the responsibility of the manufacturer.



Do not start up the unit without the ATEX fan and its air differential pressure switch both connected to the electrical panel of the unit.



The installation and electrical connection of the ATEX fan for flushing the technical compartment and the air differential pressure switch (if supplied as a kit) must be carried out by qualified technicians according to the wiring diagram supplied with the unit.



THE PERIODIC MAINTENANCE OF THE SENSOR AND ITS CALIBRATION IS MANDATORY, SEE SECTION ON SCHEDULED MAINTENANCE. After 400 cumulative days of use (of power supply), the sensor goes in alarm asking for maintenance and stopping the unit.
The alarm is reset only once the maintenance is done.



Recalibration of the sensor is required after each alarm intervention.



The sensor must be replaced if, after calibration, its sensitivity falls below 55% as specified by the manufacturer.



The sensor must be calibrated every 12 months. In any case, if more restrictive, the national legislation in force must also be applied regarding the minimum calibration interval of the sensor.

3.2 Technical data

PWE Kp		151	301
Heating capacity	kW	14,4	28,0
Input power	kW	3,7	7,4
Input current	A	7,3	14,7
COP	W/W	3,9	3,8
SCOP	W/W	4,78	5,67
Refrigerant data R290			
Refrigerant charge	kg	0,5	1,0
Global warming potential (GWP)		3	3
Equivalent CO ₂ charge	t	0,0015	0,003
Source liquid			
Liquid		Glycol	Glycol
Antifreeze content	%	24	24
Cooling capacity	kw	10,7	20,6
Inlet temperature	°C	3	3
Outlet temperature	°C	-1	-1
Flow	m ³ /h	2,43	4,68
Pressure drop	kPa	10	17,5
Heating liquid			
liquid		Water	Water
Heating capacity	kW	14,4	28
Inlet temperature	°C	40	40
Outlet temperature	°C	45	45
Flow	m ³ /h	2,5	4,87
Pressure drop	kPa	18,1	21,3
Sound data			
Sound power level ⁽¹⁾	dB(A)	74	77
Sound pressure level ⁽²⁾	dB(A)	43	46

(1) Sound power level in accordance with ISO 3744.

(2) Sound pressure level at 10 mt from the unit in free field conditions in accordance with ISO 3744.



The refrigerant data may change without notice. It is therefore necessary to refer always to the silver label placed on the unit.

3.3 Operational limits

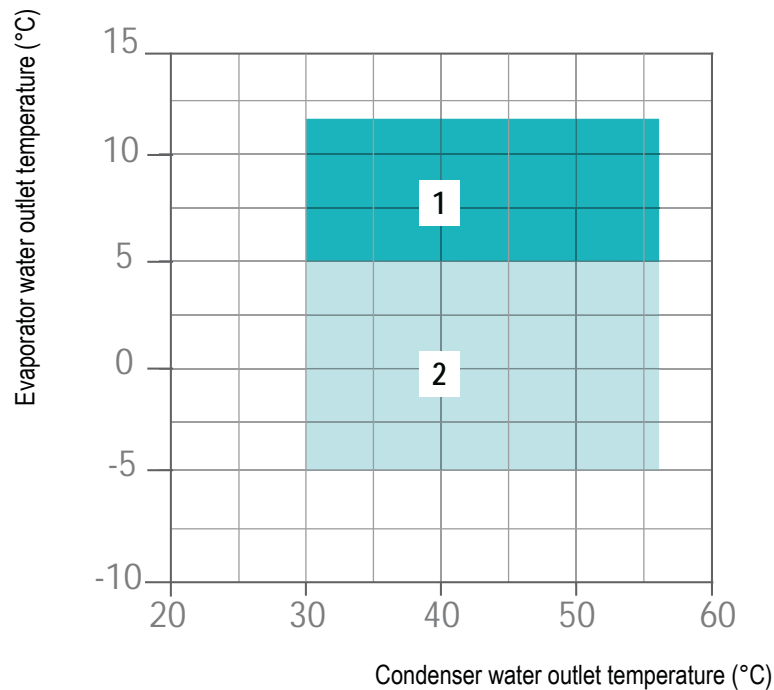

- 1 Standard unit, cooling mode
- 2 Standard unit, cooling mode with glycol

3.3.1 User heat exchanger water flow rate

The nominal water flow rate provided, relates to a ΔT of 5,5K. The maximum flow rate allowed is one that provides a ΔT of 3,5K. Higher values may cause too high a pressure drop. The minimum water flow rate allowed is that which results in a ΔT of 8K. Insufficient flow will result in evaporating temperatures that are too low leading to the operation of safety devices that will prevent unit operation.



Units are designed and manufactured to European safety and technical standards. The units have been designed exclusively for cooling and DHW production. The units must be used for this specific purpose only. The Company will not be liable for claims for damage caused to persons, animals or material goods or property caused by improper installation, adjustment and maintenance or improper use. Any use not specified in this manual is prohibited.



In case of operations outside of these values, please contact the company.



The units, in their standard configuration, are not suitable for installation in saline environments.

3.4 Correction tables

3.4.1 Operation with glycol

Glycol percentage	Freezing point (°C)	CCF	IPCF	WFCF	PDCF
10	-3.2	0.985	1	1.02	1.08
20	-7.8	0.98	0.99	1.05	1.12
30	-14.1	0.97	0.98	1.09	1.22
40	-22.3	0.965	0.97	1.14	1.25
50	-33.8	0.955	0.965	1.2	1.33

CCF: Capacity correction factor

IPCF: Input power correction factor

WFCF: Water flow correction factor

PDCF: Pressure drops correction factor

The water flow rate and pressure drop correction factors are to be applied directly to the values given for operation without glycol. The water flow rate correction factor is calculated in order to maintain the same temperature difference as that which would be obtained without glycol. The pressure drop correction factor takes into account the different flow rate obtained from the application of the flow rate correction factor.

3.4.2 Correction tables different Δt

Water temperature diff.(°C)	3	5	8
CCCP	0.99	1	1.02
IPCF	0.99	1	1.01

CCCP = Cooling capacity correction factor

IPCF = Input power correction factor

3.4.3 Correction tables different Fouling factors

Fouling factor	0.00005	0.0001	0.0002
CCCP	1	0.98	0.94
IPCF	1	0.98	0.95

CCCP = Cooling capacity correction factor

IPCF = Input power correction factor

4. INSTALLATION

4.1 General safety guidelines and use of symbols



Before undertaking any task the operator must be fully trained in the operation of the machines to be used and their controls. They must also have read and be fully conversant with all operating instructions.



All maintenance must be performed by TRAINED personnel and be in accordance with all national and local regulations.



The installation and maintenance of the unit must comply with the local regulations in force at the time of the installation.



Avoid contact and do not insert any objects into moving parts.



It is recommended that natural and accidental events such as winds of abnormal force, seismic events, fire, abnormal precipitation including snowfall, lightning, flooding and inundation be considered during the design phase of the system according to current regulations.

4.2. Health and safety Considerations



The workplace must be kept clean, tidy and free from objects that may prevent free movement. Appropriate lighting of the work place shall be provided to allow the operator to perform the required operations safely. Poor or too strong lighting can cause risks.



Ensure that work places are always adequately ventilated and that respirators are working, in good condition and comply fully with the requirements of the current regulations.

4.3 Dispositivi di protezione individuali



When operating and maintaining the unit, use the following personal protective equipment listed below as required by law.



Protective footwear.



Eye protection.



Protective gloves.



Respiratory protection.



Hearing protection.

4.4 Inspection

When installing or servicing the unit, it is necessary to strictly follow the rules reported on this manual, to conform to all the specifications of the labels on the unit, and to take any possible precautions of the case. Not observing the rules reported on this manual can create dangerous situations. After receiving the unit, immediately check its integrity. The unit left the factory in perfect conditions; any eventual damage must be questioned to the carrier and recorded on the Delivery Note before it is signed. The company must be informed, within 8 days, of the extent of the damage. The Customer should prepare a written statement of any severe damage.

Before accepting the unit check:

- The unit did not suffer any damage during transport;
- The delivered goods are conforming to what shown in the delivery note.

In Case of Damage

- List the damage on the delivery note
- Inform the Company of the extent of the damage within 8 days of receipt of the goods. After this time any claim will not be considered.
- A full written report is required for cases of severe damage.

4.5 Transport and handling

In compliance with the EN 378-1, the unit can be identified as an indirect closed system.

The refrigerant charge and type are indicated on the unit identification tag.

The unit positioning must be done considering the charge limits imposed by the EN 378-1, annex C and, in particular, by what stated in Table C1 for the refrigerant included in the group 3.

The unit handling must be done by skilled personnel only, with suitable equipment to the unit weight and dimension. During the handling operations, keep the unit in vertical position (i.e. with the basement parallel to the ground).



The transport company is always responsible for any possible damage during the transport of the goods. Before installing the unit and preparing it for the commissioning, accurately sight inspect the unit to verify the packaging integrity or that the unit has no visible damage, and oil or refrigerant leakage. Also verify that the unit complies what required in phase of order.



Any possible damage or claim must be communicated to the Manufacturer or to the carrier by means of registered mail within 8 days from goods receipt.



If one or more components are damaged, do not start the unit, and immediately inform the manufacturer, in order to agree any intervention on the unit.



It is suggested to unpack the unit at effective unit installation place. The internal handling must be done with care, avoiding using the equipment components as holds. Avoid any damage during the unit handling.



The hydraulic circuit must be fully empty before anyhow move the unit.



The units lifting must be vertical, preferably done by means of a forklift. Use a distribution beam if straps or ropes are used for the harness, carefully checking that no pressure is done on the higher edges of the unit or of the packaging.

4.6 Storage

If it is necessary to store the unit, leave it packed in a closed place. If for any reason the machine has already been unpacked, follow these instructions to prevent damage, corrosion and/or deterioration:

- Make sure that all openings are properly closed or sealed;
- Never use steam or other cleaning agents to clean the unit that could damage it;
- Remove any keys needed to access the control panel and entrust them to the site manager.



The unit can be stored at temperatures between -10°C and 60°C. When not in use, in order to prevent corrosion, deposits or breakage due to the ice formation, it is essential that the heat exchangers, on the user side, are completely empty or completely filled with water properly glycol.

4.7 Unpacking



Packaging could be dangerous for the operators.

It is advisable to leave packaged units during handling and remove it before the installation. The packaging must be removed carefully to prevent any possible damage to the machine. The materials constituting the packaging may be different in nature (wood, cardboard, nylon, etc.).



The packaging materials should be separated and sent for disposal or possible recycling to specialist waste companies.

4.8 Lifting and handling

When unloading the unit, it is strongly recommended that sudden movements are avoided in order to protect the refrigerant circuit, copper tubes or any other unit component. Units can be lifted by using a forklift or, alternatively, using belts. Take care that the method of lifting does not damage the side panels or the cover. It is important to keep the unit horizontal at all time to avoid damage to the internal components.

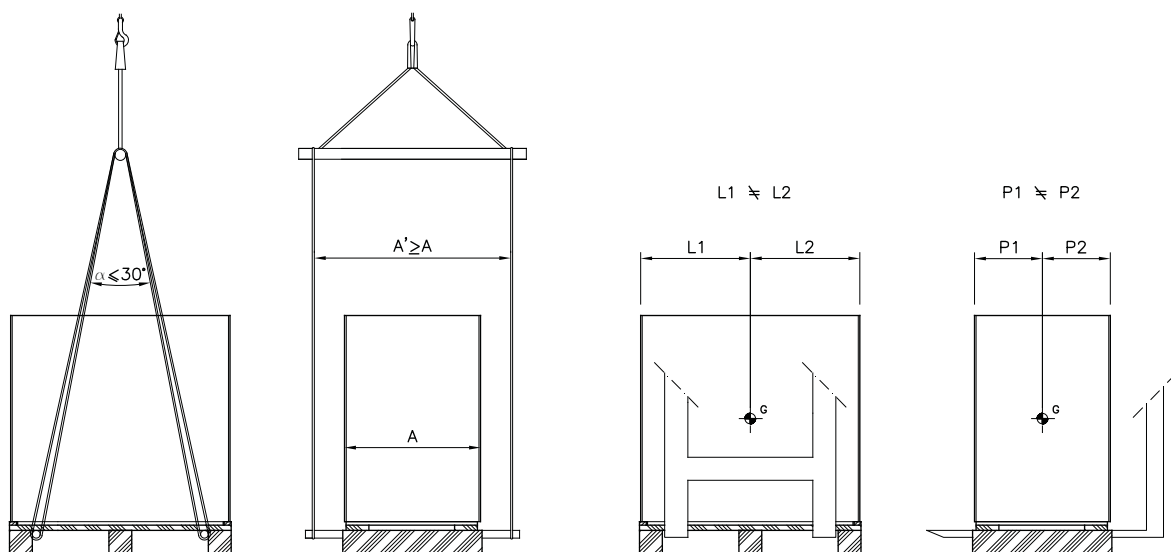

4.9 Location and minimum technical clearances

All sizes are designed and manufactured for indoor installation, inside technical rooms suitable for units charged with high flammable Propane refrigerant. Installation must be done in full compliance with applicable local laws and regulations. Before positioning the unit, it must be verified that:

- the support surface is capable of stably supporting the weight of the unit under operating conditions;
- adequate clearances are provided around the unit for routine and extraordinary maintenance as outlined.

Around the unit, in all its sides, leave at least 3m of free spaces. For safety reason, inside this area, no further devices, systems or ignition sources must be installed. Inside this area, the surfaces must no reach a temperature higher than 100K from auto-ignition temperature of the used refrigerant.

If the unit is installed in a zone with Class A (Generic) or Class B (with Supervision) presences, in compliance with the EN 378-1, par. 4.1, only the authorized person must be allowed near the unit, inside the spaces to be left free.

In any case, all the systems nearby the unit, must be filled with sand or equipped with siphon. The underground pipelines must be positioned at 0.80 m under the ground level at least.

The systems must be inspected every 6 months at least, in order to verify that the taken precaution to avoid the propagation of explosive atmospheres are efficient.



The unit has to be installed such that maintenance and repair is possible. The warranty does not cover costs for the provision of lifting apparatus, platforms or other lifting systems required to perform repairs during warranty period.



The installation site should be chosen in accordance with EN 378-1 and 378-3 standards. When choosing the installation site, all risks caused by accidental refrigerant leakage should be taken into consideration.



The unit must be positioned as much far as possible, and anyway at 3 m minimum, from drainage or electrical systems, in order to avoid the spread of potentially explosive atmospheres, in case of refrigerant leakages.

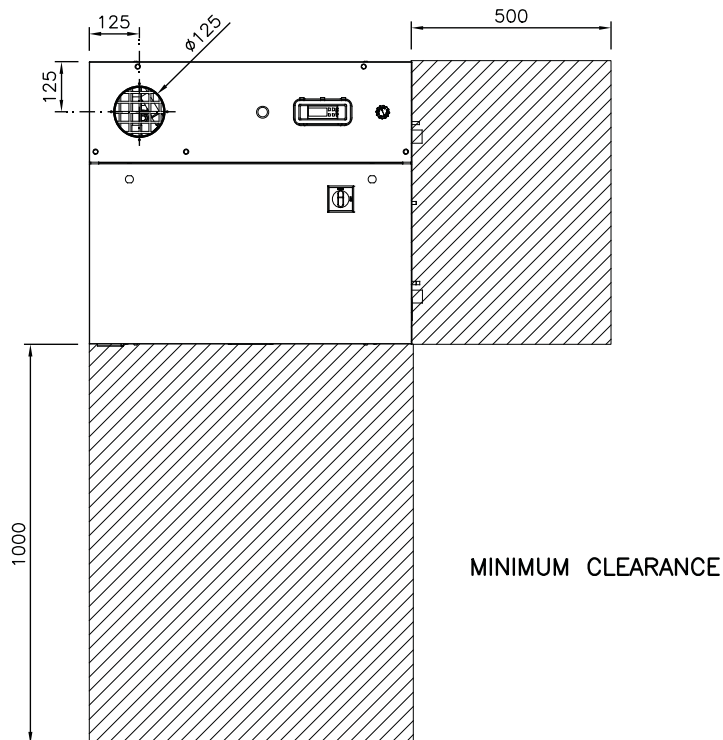

4.10 Hydraulic connections

The water pipe-work must be installed in accordance with national and local regulation and can be made from copper, steel, galvanized steel or PVC. The Pipework must be designed to cater for the nominal water flow and the hydraulic pressure drops of the system. All pipes must be insulated with closed-cell material of adequate thickness. The hydraulic piping should includes:

- Pockets for temperature sensor to measure the temperature in the system.
- Flexible joints, to isolate the unit from the rest of the system.
- Temperature and pressure gauges for maintenance and servicing operations.
- Shut-off manual valves to isolate the unit from the hydraulic circuit.
- Metallic filters to be mounted on the inlet pipe with a mesh not larger than 1 mm.
- Vent valves, expansion tank with water filling, discharge valve.



The hydraulic connection diameters are specified in the "Technical Data" table.



System return water must be fitted to the connection labelled: "USER WATER IN" as incorrect connection can damage the heat exchanger by freezing.



It is compulsory to install on the USER WATER IN connection, a water strainer with a mesh not larger than 1 mm. Fitting this filter is **COMPULSORY** and the warranty will be invalidated if it is removed. The filter must be kept clean and checked periodically.

The connection of the unit to the hydraulic circuit must be carried out by an experienced and qualified technician in accordance with the local regulations in force.



The connection of the unit to the system must be carried out in such a way that the fluid to be cooled circulates in the evaporator in the correct direction. To this purpose, the pipes must be connected in compliance with the instructions given in the connection on the unit.



In case of breaking of the user side exchanger, the refrigerant can enter the water circuit. Position then the vent valves of the system in airy zone and far from manholes where the refrigerant could be concentrated, creating potentially explosive atmospheres. If not possible, the closed ambient where these vent valves are present, must be arranged with the precautions stated in the EN-378.

To connect the pipes to the evaporator, take care of the following advises:

- Connect the pipes as shown in picture

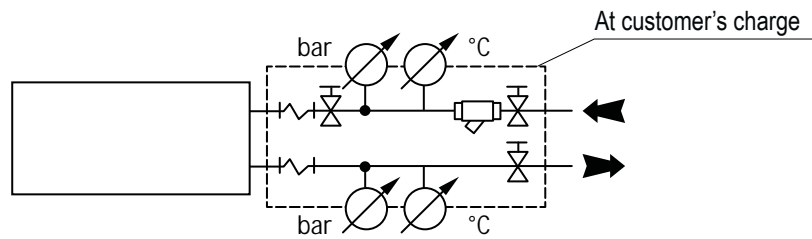

- To avoid any vibration transmission and permit the thermal expansions, anti-vibration fittings must be installed on the pipes ;
- To avoid the inlet of foreign bodies and particles, you need to install, on unit inlet, a cleanable mechanic filter, with mesh dimension not larger than 1mm and with suitable nominal diameter, to reduce pressure drops;
- The installation of shut-off valve up and down stream of the filter is recommended, in order to make the cleaning operation simpler and quicker;
- The installation of thermometers and gauges near the inlet and outlet connection of the device, make the check of the unit operation easier;
- The chilled water system must be coated with close-cells anti-condensation material, with thermal insulation characteristics, vapor impermeability and with suitable thickness for the worst foreseeable conditions, in operation and stand-by mode;
- Use the pre-arranged connection shown in the attached dimensional drawing to connect the unit to the hydraulic system;
- Once the circuit is done and the unit installed, seal test of the whole system must be done, in order to find out any possible leakage and repair it, before the circuit filling and commissioning.



After the seal test, if the start-up of the system is planned after a long period of stop or if the ambient temperature can go down till values near to 0°C or lower, you need to drain the water from the circuit or enter a suitable percentage of glycol.



If the pump group for the fluid circulation inside the evaporator is not supplied with the unit, be sure that the compressors start only after that the pump group is on.



When starting the unit for the first time, it is necessary to load it with clean water with chemical-physical characteristics such as to prevent corrosive phenomena or deposits of any kind. For this purpose, it is advisable to check annually the stability of the pH.

4.11 Chemical characteristics of the water

In the following table there are, just as an indication, the main values of chemical and physical properties of the water to be respected to avoid corrosion or any sediment. To this purpose it is advisable yearly check PH stability.

<p>Table key</p> <p>+ Good resistance under normal conditions</p> <p>0 Corrosion problems may occur especially when more factors are valued 0</p> <p>- Use is not recommended</p>	<p>Important Note: The following parameters can also influence the corrosion resistance</p> <p><u>Temperature:</u> The data in the table are based water temperature of 20°C unless otherwise is stated.</p> <p><u>Presence of oxidants</u> in the environment: guidelines regarding the oxygen content are shown in Table 3.</p> <p><u>Product form</u>, heat treatment and presence of intermetallic phases: The data in the table is based on untreated raw material.</p>
--	---

WATER CONTENT	CONCENTRATION (mg/l or ppm)	TIME LIMITS Analyze before	Plate Material		Brazing Material		
			AISI 304	AISI 316	COPPER	NICKEL	STAINLESS STEEL
Alkalinity (HCO ₃ ⁻)	< 70	Within 24 h	+	+	0	+	+
	70-300		+	+	+	+	+
	> 300		+	+	0/+	+	+
Sulphate ^[1] (SO ₄ ²⁻)	< 70	No limit	+	+	+	+	+
	70-300		+	+	0/-	+	+
	> 300		+	+	-	+	+
HCO ₃ ⁻ / SO ₄ ²⁻	> 1.0	No limit	+	+	+	+	+
	< 1.0		+	+	0/-	+	+
Electrical conductivity ^[2] (Refer to Table 3 for oxygen content guidelines)	< 10 µS/cm	No limit	+	+	0	+	+
	10-500 µS/cm		+	+	+	+	+
	> 500 µS/cm		+	+	0	+	+
pH ^[3]	< 6.0	Within 24 h	0	0	0	+	0
	6.0-7.5		+	+	0	+	+
	7.5-9.0		+	+	+	+	+
	9.0-10		+	+	0/+ ^[4]	+	+
	>10.0		+	+	0	+	+
Ammonium (NH ₄ ⁺)	< 2	Within 24 h	+	+	+	+	+
	2-20		+	+	0	+	+
	>20		+	+	-	+	+
Chlorides (Cl ⁻) (Refer to Table 2 for temperature- dependent values)	<100	No limit	+	+	+	+	+
	100-200		0	+	+	+	+
	200-300		-	+	+	+	+
	300-700		-	0/+	0/+	+	-
	>700		-	-	0	+	-
Free chlorine (Cl ₂)	< 1	Within 5 h	+	+	+	+	+
	1-5		-	-	0	+	-
	> 5		-	-	0/-	+	-
Hydrogen sulfide (H ₂ S)	< 0.05	No limit	+	+	+	+	+
	>0.05		+	+	0/-	+	+
Free (aggressive) carbon dioxide (CO ₂)	< 5	No limit	+	+	+	+	+
	5-20		+	+	0	+	+
	> 20		+	+	-	+	+
Total hardness ^[5] (Refer to "Scaling Document" for scaling aspect of hardness effect)	4.0 - 11 °dH	No limit	+	+	+	+	+
	70 - 200 mg/l CaCO ₃		+	+	+	+	+
Nitrate ^[1] (NO ₃ ⁻)	< 100	No limit	+	+	+	+	+
	> 100		+	+	0	+	+
Iron ^[6] (Fe)	< 0.2	No limit	+	+	+	+	+
	> 0.2		+	+	0	+	+
Aluminium (Al)	< 0.2	No limit	+	+	+	+	+
	> 0.2		+	+	0	+	+
Manganese ^[6] (Mn)	< 0.1	No limit	+	+	+	+	+
	> 0.1		+	+	0	+	+

CHLORIDE CONTENT	MAXIMUM TEMPERATURE					
	20°C	30°C	60°C	80°C	120°C	130°C
= 10 ppm	SS 304	SS 304	SS 304	SS 304	SS 304	SS 316
= 25 ppm	SS 304	SS 304	SS 304	SS 304	SS 316	SS 316
= 50 ppm	SS 304	SS 304	SS 304	SS 316	SS 316	Ti
= 80 ppm	SS 316	SS 316	SS 316	SS 316	SS 316	Ti
= 200 ppm	SS 316	SS 316	SS 316	SS 316	Ti	Ti
= 300 ppm	SS 316	SS 316	SS 316	Ti	Ti	Ti
=700 ppm	SS 316	SS 316	Ti	Ti	-	-
=1000 ppm	SS 316	Ti	Ti	Ti	-	-
> 1000 ppm	Ti	Ti	Ti	Ti	-	-

In order to prevent corrosive phenomena or deposits of any nature it is recommended to:

- Empty the evaporator before any maintenance work is carried out;
- Do not clean the evaporator with unsuitable mechanical systems, such as drill bits or high-pressure jets;
- Do not clean with too aggressive cleaning agents. Before using a chemical detergent, check the compatibility with the construction materials of the exchanger.
- During winter stops, carefully empty the heat exchanger.



In case of long stops, leave the heat exchanger completely filled with adequate glycol water or completely empty.

4.12 User circuit minimum water content



Each chiller requires a minimum water content within the hydraulic circuit of the user, in order to ensure proper operation of the unit, preventing a large number of starts and stops of the compressors that could reduce the life cycle of the unit itself.

PWE Kp	151	301
Minimum (l)	300	300

4.13 Filling the hydraulic circuit

- Before filling, check that the installation drain valve is closed.
- Open all pipework, heat pump and terminal unit air vents.
- Open the shut off valves.
- Begin filling, slowly opening the water valve in the filling group outside the unit.
- When water begins to leak out of the terminal air vent valves, close them and continue filling until the pressure gauge indicates a pressure of 1.5 bars.

The installation should be filled to a pressure of between 1 and 2 bars. It is recommended that this operation be repeated after the unit has been operating for a number of hours (due to the presence of air bubbles in the system). The pressure of the installation should be checked regularly and if it drops below 1 bar, the water content should be topped-up. If frequent top-ups are required, check all connections for leaks.

4.14 Emptying the installation

- Before emptying, place the mains switch in the “Off” position.
- Make sure the filling group valve is closed.
- Open the drainage valve outside the unit and all the installation and terminal air vent valves.



If the fluid in the circuit contains anti-freeze, it **MUST** not be allowed to run away to drain. It must be collected for possible re-cycling or for correct disposal.

4.15 Electric connections: preliminary safety information

The electric panel is located inside the unit at the top of the technical compartment where the various components of the refrigerant circuit are also to be found. To access the electrical board, remove the front panel of the unit:



Power connections must be made in accordance to the wiring diagram enclosed with the unit and in accordance to the norms in force.



Make sure the power supply upstream of the unit is (blocked with a switch). Check that the main switch handle is padlocked and it is applied on the handle a visible sign of warning not to operate.



It must be verified that electric supply is corresponding to the unit electric nominal data (tension, phases, frequency) reported on the label in the front panel of the unit.



Power cable and line protection must be sized according to the specification reported on the form of the wiring diagram enclosed with the unit.



The cable section must be commensurate with the calibration of the system-side protection and must take into account all the factors that may influence (temperature, type of insulation, length, etc.).



Power supply must respect the reported tolerances and limits: If those tolerances should not be respected, the warranty will be invalidated.



Flow switches must be connected following the indication reported in the wiring diagram. Never bridge flow switches connections in the terminal board. Guarantee will be invalidated if connections are altered or not properly made.

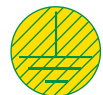

Make all connections to ground provided by law and legislation.



Before any service operation on the unit, be sure that the electric supply is disconnected.



The power line and the unit external safety devices must be sized in order to ensure the correct voltage at the maximum operating conditions of the unit reported in the wiring diagram of the unit.



FROST PROTECTION

If opened, the main switch cuts the power off to any electric heater and antifreeze device supplied with the unit, including the compressor crankcase heaters. The main switch should only be disconnected for cleaning, maintenance or unit repair.

The unit must be powered by a 5-wire cable (3 phases +GND + N).

Connect the phases to the input clamp of the main switch and the ground conductor to the dedicated clamp. Use a power supply cable with suitable section and as short as possible to avoid voltage drops.

Protect the power supply cable upstream the unit by means of an automatic switch with suitable size and features. The power supply cable section and the automatic switch size, can be found in the electrical components table attached, as well as the main switch size.

The cable entry is shown in the dimensional drawing of the unit attached to the Handbook. It must be suitably protected in compliance with the local regulations in force.

If the power supply cable entry is from the top, make a drop-break fold.



Before anyhow intervene on the unit, slightly verify that the electrical circuits of the device have not been damaged during the transport. Especially check that all the screws of the clamps are correctly tightened, and that the cable insulation is intact and in good conditions.

The conductors for the phases power supply cable, must be connected to the free clamps to the unit main switch entry; the ground conductor must be connected to the dedicated pre-arranged clamp (PE).

4.16 Electric data



The electrical data reported below refer to the standard unit without accessories.
In all other cases refer to the data reported in the attached electrical wiring diagrams.



The line voltage fluctuations can not be more than $\pm 10\%$ of the nominal value, while the voltage unbalance between one phase and another can not exceed 1%, according to EN60204. If those tolerances should not be respected, please contact our Company. **The use of the unit with a power supply with higher variations than those indicated will invalidate the warranty.**

PWE Kp		151	301
Power supply	V/~ /Hz	400/3/50 + GND + N	400/3/50 + GND + N
Control board	V	24 Vac	24 Vac
Auxiliary circuit	V/~	24/230 Vac	24/230 Vac
Line section	mm ²	4	6
PE section	mm ²	4	6

5. UNIT START UP

5.1 Preliminary checks

Before starting the unit the checks detailed in this manual of the electric supply and connections, the hydraulic system and the refrigerant circuit, should be performed.



Start-up operations must be performed in accordance with the instructions detailed in the previous paragraphs.



If it is required to switch the unit on and off, never do this using the main isolator: this should only be used to disconnect the unit from the power supply when the unit is to be permanently off. Isolation will result in no supply for the crankcase heater and on start up the compressor could be seriously damaged.

5.1.1 Before start-up



Damage can occur during shipment or installation. It is recommended that a detailed check is made, before the installation of the unit, for possible refrigerant leakages caused by breakage of capillaries, pressure switch connections, tampering of the refrigerant pipework, vibration during transport or general abuse suffered by the unit.

- Verify that the unit is installed in a workmanlike manner and in accordance with the guidelines in this manual.
- Check that all power cables are properly connected and all terminals are correctly fixed.
- The operating voltage between phases R S T is the one shown on the unit labels.
- Check that the unit is connected to the system earth.
- Check that there is no refrigerant leakage.
- Check for oil stains, sign of a possible leak.
- Check that the refrigerant circuit shows the correct standing pressure on the pressure gauges (if present) otherwise use external ones.
- Check that the Schrader port caps are the correct type and are tightly closed.
- Check that crankcase heaters are powered correctly (if present).
- Check that all water connections are properly installed and all indications on unit labels are observed.
- The system must be flushed, filled and vented in order to eliminate any air.
- Check that the water temperatures are within the operation limits reported in the manual.
- Before start up check that all panels are replaced in the proper position and locked with fastening screws.
- Before start-up, check that all the water taps on the compressor outlets are open.



Do not modify internal wiring of the unit as this will immediately invalidate the warranty.



Crankcase heaters must be powered at least 12 hours before start up (pre-heating period) To do this, isolate the compressor(s), fans and pump(s) in the electrics box and then switch on the main isolator (heaters are automatically supplied when the main switch is closed). The crankcase heaters are working properly if, after several minutes, the compressor crankcase temperature is about 10÷15°C higher than ambient temperature.



During the 12 hours pre-heating period it is also important to check that the label OFF is shown on the display or that the unit is on stand-by mode. If there is an accidental start-up before the 12 hours pre-heating period has elapsed, the compressors could be seriously damaged and therefore the warranty will immediately terminate .

5.1.2 Commissioning

The unit commissioning must be carried-out by a skilled refrigeration technician authorized by the manufacturer.



Before switching the unit ON check that all the shut-off valves on compressors discharge side are open.



Before starting the unit for the first time or after a long period of stop, verify that the parameters set on the microprocessor are coherent with the required working conditions.

To switch the device ON, turn the main switch to ON, to power the unit. Then press the ON/OFF key on the microprocessor keyboard, positioning it on ON.

If the remote ON/OFF contact is closed, the circulation water pump, if present, will immediately start. After a delay time, settable by microprocessor, also the fans will start and then the different compressors in relation to the required cooling capacity to satisfy the present thermal load.

Once the unit has reached a stable operation regime, the technicians must verify the group working parameters and verify that:

- the safety high pressure switches are right installed and calibrated;
- on the external safety valves it is shown the calibration pressure and that the value is the one foreseen.
- No refrigerant leakage is present

The collected data must to be recorded on the commissioning report attached to this manual.



A copy of the commissioning report, duly filled, must be sent to the manufacturer, to make the warranty valid.



During the commissioning, the technician must check that the safety (high and low pressure switches, water differential pressure switch, anti-freeze thermostat etc.) and control devices (regulation thermostat, condensation pressure regulation device etc) properly work.

5.1.3 Device and security Set-point

Device		Set-point	Differential	Reset
Cooling mode	°C	23	2	----
DHW mode	°C	50 * **	2	----
Anti-freeze thermostat	°C	4,5	2	Manual
High-pressure safety valve	Bar	23	----	----
High pressure switch	Bar	22	----	Manual
Low pressure switch	Bar	1,5***	1	Automatic

* Default values. Different values can be set on request

** With RP accessory

*** Water outlet -1°C

5.1.4 Controls during unit operation

After several hours of operation, check that the sight glass has a green colour core: if the core is yellow moisture is present in the circuit. In this event it is necessary for dehydration of the circuit to take place. This must be performed by qualified people only. Check that there are no continuous vapour bubbles present at the sight glass. This would indicate a shortage of refrigerant. A few vapour bubbles are acceptable.

5.1.5 Safety valves

The outlet connections of the safety valves installed on the unit are provided with a threaded connection, which must be connected to a safe area at a height of not less than 3 metres from the machine and any other sources of ignition. If provided, the valves must be directed in metal piping, to an area where the refrigerant spill cannot damage people or things.

The piping must be made according to the EN378 and EN13136 regulations and to any regulations in force.



The piping for conveying into a safe area must allow the release of the refrigerant upwards, away from the machine, from potential triggers from doors, windows or other entrances to closed environments.



The refrigerant spilled from safety valves is an high pressure, high temperature and high speed discharged gas. Its flow may damage things and people coming in direct contact with it.



The opening of safety valves comes with a noise whose intensity may damage hearing capabilities of surrounding people.



The representative cone that forms following the opening of the safety valve can expand for more than 5m from the release point.

SAFETY VALVE FEATURES (R290)

PWE	Discharge flow rate (*) (Kg/h)	Setting pressure (bar)	kd	Ac (mmq)
151 Kp	992	23	0,94	30,8
301 Kp	992	23	0,94	30,8

(*) Calculated according to EN13136

5.1.6 Leak detection sensor

When unit is switched on, the sensor is heated/initialised (for some minutes). During this period the led lights inside the sensor flash, leakage alarm (Alarm lamp ON) is indicated on the Q.E. panel, the 24 Vac control auxiliary circuit is not supplied and there is a forced washing through the extraction fan. After this, if no signal arrives from the sensor, the

At unit start, there is the heating/initializing of the sensor (for some minutes). During this period the internal sensor LEDs flash, the leakage alarm is signalled, with relevant light alarm on the electrical panel, the 24 Vac auxiliary circuit is not powered and a forced washing through the extraction fan is activated. After that, no further signals arrive from the sensor, the control PLC is powered ON and the unit is ready to work. Without refrigerant leakage alarm, the forced washing is cyclically made, 2' per hour, but a different timing can be set through a timer. With refrigerant leakage, the sensor activates and the leakages signalling led immediately lights, powering the control PLC OFF and activating the washing fan. The ventilation keeps ON as long as the leakage sensor signals refrigerant presence.

The sensor has got 2 different alarm levels:

- The first one set at 20% of the LOWER FLAMMABLE LIMIT (LFL) with automatic reset; when the alarm is solved, the extraction fan stops, the led turns off and the PLC is again powered to return to the normal operation;
- The second one set at 30% of the LFL with manual reset; in this case, the extraction fan and the signal led will remain active and the PLC not powered till the alarm will be manually reset (disconnecting the sensor power supply or pressing the reset key inside the sensor itself)



The red lamping signal on the door of the electrical panel indicates the refrigerant leakage and also the extraction fan thermal alarm (to be manually reset inside the electrical cabinet), in this case the extraction fan will stop, the forced washing is not done anymore and PLC is stopped.

5.2 Description of the control panel



5.2.1 Display symbol

The instrument display is divided into three zones:

Left zone: the display shows the icons.

Top right zone: the display shows the inlet water temperature.

Bottom right zone: The display shows the temperature of water utilities in output or, in the version with condensation control, the pressure of evaporation / condensation.

Icon	Meaning	Icon	Meaning
°C	Celsius degrees		Electric heaters activated
bar	Bar		User water pump
	Compressor 1	Flow!	Water flow alarm
	Compressor 2		External fan
	General Alarm		

5.2.2 Function of keys



M makes it possible to enter the functions menu



SET makes it possible to display or modify the set points . Selects a parameter or confirms a value in programming mode.



In standard mode allows the display of the different temperatures
 1 click: Bottom line displays **Pb1**: User inlet water temperature
 2 clicks: Bottom line displays **Pb2**: User outlet water temperature
 3 clicks: Bottom line displays **Pb3**: refrigerant pressure (high pressure in cooling, low pressure in heating mode)
 4 clicks: Bottom line displays **Pb4**: Finned coil temperature (not used)
 In programming mode it allows the user to scroll through the parameter codes or to increase values.



In standard mode it allows the display of the different temperatures in the opposite way to the above arrow. In programming mode it allows the user to scroll through the parameter codes or to decrease values.



If pressed down for 5 seconds, it makes it possible to switch the unit on or off in chiller mode. Each time this function is activated, the green led positioned just above the button will be switched ON.



If pressed down for 5 seconds, it makes it possible to switch the unit on or off in heating mode. Each time this function is activated, the green led positioned just above the button will be switched ON.

5.3 Remote control panel



5.3.1 Display symbol

Icon	Meaning	Icon	Meaning
°C	Celsius degrees		Electric heaters activated
bar	Bar		User water pump
	Compressor 1	Flow!	Water flow alarm
	Compressor 2		External fan
	General Alarm		

5.3.2 Function of keys



M makes it possible to enter the functions menu



SET makes it possible to display or modify the set points . Selects a parameter or confirms a value in programming mode.



In standard mode allows the display of the different temperatures
 1 click: Bottom line displays **Pb1**: User inlet water temperature
 2 clicks: Bottom line displays **Pb2**: User outlet water temperature
 3 clicks: Bottom line displays **Pb3**: refrigerant pressure (high pressure in cooling, low pressure in heating mode)
 4 clicks: Bottom line displays **Pb4**: Finned coil temperature (not used)
 In programming mode it allows the user to scroll through the parameter codes or to increase values.



In standard mode it allows the display of the different temperatures in the opposite way to the above arrow. In programming mode it allows the user to scroll through the parameter codes or to decrease values.



If pressed down for 5 seconds, it makes it possible to switch the unit on or off in chiller mode. Each time this function is activated, the green led positioned just above the button will be switched ON.



If pressed down for 5 seconds, it makes it possible to switch the unit on or off in heating mode. Each time this function is activated, the green led positioned just above the button will be switched ON.

5.3.3 Installation

The remote control panel is mounted on a panel with 72x56 mm cut-out, fixed with screw.

To obtain IP65 protection for the panel, use the rubber gasket RGW-V (optional). For wall mounting use the V-KIT plastic adapter as illustrated in the picture.

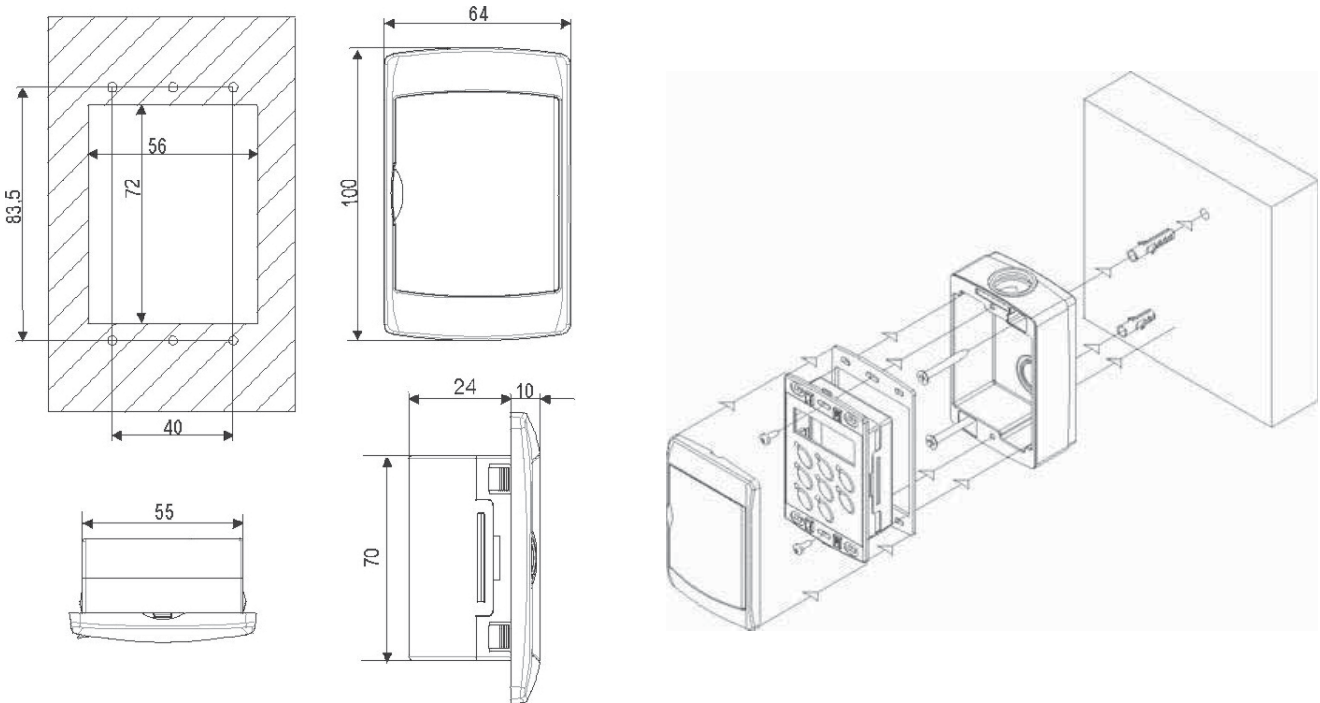

Electric data can be updated without notice. It is therefore necessary to always refer to the wiring diagram provided in the unit.



If there is damage to the remote control or there is a faulty connection, failure of communication will be indicated in the display with the message "noL" (no link).

6. USE

6.1 Switch the unit on

In order to power the unit, turn the main switch to the ON position. The display shows the User inlet water temperature.

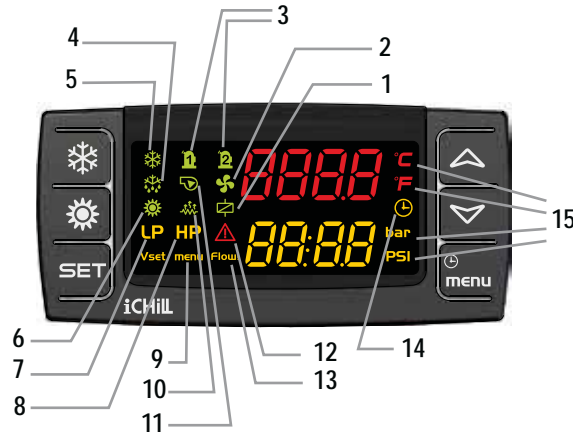

Legend

1	Icon on if the open collector outlet is active.	9	Function menu active.
2	Icon ON (acceso): if the fans are running.	10	Integrative user circuit heaters activated.
3	Icon On if the compressor is turned on; Icon blinking if the compressor is in the ignition timing.	11	Icon on if at least one of the 2 water pumps (pump evaporator or pump condenser) is on.
4	Icon blinking: Defrost cycle timeout activated; Led ON: Defrost cycle activated.	12	Icon blinking on alarm.
5	Icon ON: Unit in cooling mode.	13	Icon blinking if the digital input of the flow switch is active (both pump ON and pump OFF).
6	Icon ON: Unit in heating mode.	14	Icon on when the bottom display show current time, the hours of operation of the loads, etc.
7	Icon blinking if low pressure alarm is active.	15	Icon on when the display show a temperature or a pressure.
8	Icon blinking if high pressure alarm is active.		

6.1.1 Cooling mode

To start the unit in heating mode, press the key. The snowflake icon is on. If requested, the compressor safety delay countdown starts and the compressor icon flashes. The water pump will be activated after few seconds and then, once the compressor countdown has finished, the compressor starts and the icon remains on. The display shows the user water inlet temperature.

6.1.2 Heating mode

To start the unit in heating mode, press the key. The sun icon is on. If requested, the compressor safety delay countdown starts and the compressor icon flashes. The water pump will be activated after few seconds and then, once the compressor countdown has finished, the compressor starts and the icon remains on. The display shows the user water inlet temperature.

6.2 Stop

6.2.1 Cooling mode

To stop the unit in cooling mode, press the  key. The LED switches off. The unit goes into stand-by mode.

6.2.2 Heating mode

To stop the unit in heating mode, press the  key. The LED switches off. The unit goes into stand-by mode.

6.3 Stand-by

When the unit is switched off from the keyboard or the remote panel, it goes into standby mode. In this mode, the microprocessor control displays the sensor readings and is also able to manage alarm situations. The only visible signal on the display is the green led of circuit1 and the water temperatures. If the unit is switched off from remote ON/OFF the label OFF is displayed.



If it is required to switch the unit on and off, never do this using the main isolator: this should only be used to disconnect the unit from the power supply when the unit is to be permanently off. Isolation will result in no supply for the crankcase heater and on start up the compressor could be seriously damaged.

6.4 How to change the set points



When modifying or varying the machine's operating parameters, make sure that you do not create situations that conflict with the other set parameters.



The complete display of the 2 set points (heating, cooling) is ONLY available when the unit is in stand-by mode. It is suggested to put the unit in stand by when modifying set points. If the unit is not in stand-by, the only editable parameters are the ones related to the operation mode of the unit (eg. In heating mode it is only possible to change the heating and set points, in cooling mode it is only possible to change the cooling and set points.)



Select the required set point using the Press the  key . The label appears at the bottom of the display:

SEtH Heating set point

SEtC Cooling set point.

To set the required set-points press again the  for 3 seconds.

The current value flashes at the top and can be modified using the  ,  keys we can modify the parameter.

Then press the  key to memorise the parameter and exit.



All set points are intended as return temperature from the plant. For example: if hot water at 45°C is required and the Δt is 5°C, than the set point will be 40°C. If the Δt is 8°C, then the set point has to be set at 37°C. If, for example, cold water is required at 15°C and the Δt is 5°C, then the set point will be 20°C. If the Δt is 8°C, then the set point has to be set at 23°C.

6.4.1 Adjustable parameters

The adjustable set points that can be modified by the end user are:



Label	Function	Adjustment limit	Default value
SEt H	Heating set-point	20÷55°C	40°C
SEt C	Cooling set-point	10÷23°C	12°C
PAS	Password	(Contact the company)	



The units are supplied with a very sophisticated control system with many other parameters that are not adjustable by the end user; these parameters are protected by a manufacturer password.

6.5 Parameters list

By pressing the  key the user has the possibility to display many parameters.





Scroll the list of the parameters using the  ,  keys, then press the  key to display the required one. In this menu it is only possible to display the parameters, it is not possible to change any value. The parameter list is:

Display	List	Symbol	Meaning
ALrM	Alarm List	ALrM	See following paragraph
ALOG	Alarm history	ALOG	See following paragraph
HouR	Main components working hours	C1HR	Working hours compressor 1
		C2HR	Working hours compressor 2 (only models with 2 compressors)
		PFHR	Working hours user water pump
		PCHR	Working hours domestic hot water pump
DEF	(Not used)	dF1	Countdown (in seconds) to the next defrost cycle; the countdown is active if the defrost led  is blinking. In case the defrost led is off the defrost cycle is not required. During the defrost cycle the defrost led is ON.

6.6 Acoustic signal silencing

Pressing and releasing one of the keys; the buzzer is switched off, even if the alarm condition remains in place.

6.7 Alarm reset

Press the  key (the menu ALrM appears at the bottom right of the display). Press the  key to display the alarm event. In case of multiple alarms use the using the  ,  keys, to scroll through the list of the active alarms.

There are two types of alarms:







Reset alarms:

RST label appears on the upper part of the display. In this case press the  key to reset.

Non reset alarms:

nO label appears on the upper part of the display. In this case the alarm is permanent; contact technical support.

6.8 Display alarm history

Press the  key, then the  ,  keys, to scroll through the menus, when ALOG label appears in the bottom part of the display, press  . To scroll the list of alarms use the  ,  keys.

7. MAINTENANCE OF THE UNIT

7.1 General warnings

Maintenance can:

- Keep the equipment operating efficiently
- Prevent failures
- Increase the equipment life



It is advisable to maintain a record book for the unit which details all operations performed on the unit as this will facilitate troubleshooting.



Maintenance must be performed in compliance with all requirements of the previous paragraphs.



Use personal protective equipment required by regulations as compressor casings and discharge pipes are at high temperatures. Coil fins are sharp and present a cutting hazard.



If the unit is not to be used during the winter period, the water contained in the pipes may freeze and cause serious damage. In this event, fully drain the water from the pipes, checking that all parts of the circuit are empty including any internal or external traps and siphons.



If the unit is not used for long or during the seasonal stops, do not forget to close the shut-off valve on compressor discharge side.



Inside the unit, there can be high voltage zones. Any intervention on them, must be done by authorized personnel qualified in compliance with the local regulations in force.



The surfaces of the components in the compressor discharge side and in the refrigerant liquid line could reach very high temperatures and any contact can cause burns.



Before carrying out any kind of work on the machine, it is necessary to cut off the power supply from the electric panel, by turning the main switch to the OFF position



To carry on any intervention requiring the opening of the cooling circuit, follow this procedure:

- 1) activate the crankcase heater of the compressor for 4 hours minimum-
- 2) recover the refrigerant by means of an approved cylinder
- 3) make the vacuum in the circuit
- 4) flow the circuit with inert gas (nitrogen)
- 5) use orbital blades to dissect the pipes



Smoking is forbidden during maintenance operations.

7.2 Drive access

Access to the unit once installed, should only be possible to authorized operators and technicians. The owner of the equipment is the company legal representative, entity or person owns the property where the machine is installed.

They are fully responsible for all safety rules given in this manual and regulations. If it is not possible to prevent access to the machine by outsiders, a fenced area around the machine at least 1.5 meters away from external surfaces in which operators and technicians only can operate, must be provided.

7.3 Routine maintenance

The Owner must take care that the unit is adequately maintained, according to the indications contained in the Handbook and what required by current local laws and regulations.

The Owner must take care that the unit is periodically suitably inspected and maintained, according to the system type, size, age and functions and to the indication in the Handbook.



If leak detection instruments are installed on the system, they must be inspected at least once a year, to check that they work properly.

During its operation life the unit must be inspected and checked as stated by the current local laws and regulation. In particular, unless more restrictive specifications, follow the recommendation on the following table (see. EN 378-4. encl. D).

CASE	Sight Inspection (par. 4.2, p.ti a - l)	Pressure test	Leak detection
A	X	X	X
B	X	X	X
C	X		X
D	X		X

A	Inspection, after an intervention, with possible effects on the mechanical resistance or after a change of purpose or after a stop longer than 2 years; all unfit components must be replaced. Do not carry on checks with higher pressures than design ones.
B	Inspection following an intervention, or a relevant modification of the system or its components. The check can be restricted to the components involved in the intervention, but if a refrigerant leak is detected, a leak detection must be made on the all system.
C	Inspection following a change of the unit position. If there is the chance to have effects on the mechanical resistance, refer to point A.
D	Refrigerant leak detection after a justified suspicious. The system must be checked to find any leaks, using direct measures (devices able to find the leak) or indirect ones (deduction of the leak presence analysing the operational parameters), focusing attention on those parts which are more easily exposed to leaks (junctions, for example).



If it is detected a fault that endangers the reliable operation of the unit, it's necessary to rectified it before restart the unit.

7.4 Periodical checks



The start-up operations should be performed in compliance with all requirements of the previous paragraphs.



All of the operations described in this chapter **MUST BE PERFORMED BY TRAINED PERSONNEL ONLY**. Before commencing service work on the unit ensure that the electric supply is disconnected. The top case and discharge line of compressor are usually at high temperature. Care must be taken when working in their surroundings. Aluminium coil fins are very sharp and can cause serious wounds. Care must be taken when working in their surroundings. After servicing, replace the cover panels, fixing them with locking screws.

7.4.1 Electrical system and control devices

Actions	Frequency						
	Daily	Monthly	Every 2 months	Every 6 months	Once a year	Every 5 years	If required
Check that the unit works properly and that there are no alarms	X						
Visually inspect the unit		X					
Check unit noise and vibration		X					
Check safety devices and interlocks				X			
Check the unit performances				X			
Check the absorbed current of the components (compressors, fans, pumps, etc.)				X			
Check the supply voltage of the unit				X			
Check the connection of cables to the pre-arranged clamps				X			
Check the integrity of the insulating coating of the electrical cables					X		
Check contactors conditions and functioning					X		
Check microprocessor and display functioning			X				
Check microprocessor set parameter values					X		
Eliminate any dust from electrical and electronic components				X			
Check probes and transducers functioning and calibration					X		
Check evaporator refrigerant level sensor functioning (if present)					X		
Check evaporator refrigerant level sensor calibration (if present)					X		
Check the calibration of the refrigerant leakage sensor					X		

7.4.2 Condensing coils fans and cooling circuit

Actions	Frequency						
	Daily	Monthly	Every 2 months	Every 6 months	Once a year	Every 5 years	If required
Visually inspect condensing coil		X					
Clean finned coils ⁽¹⁾ (if present)				X			
Check the water flow and/or any leaks		X					
Check that the flow switch is working properly				X			
Clean the metallic filter on the water pipe ⁽³⁾				X			
Check fans noise and vibration (if present)		X					
Check fans supply voltage (if present)				X			
Check fans electrical connection (if present)					X		
Check proper operation and calibration of the fans speed regulation system (if present)					X		
Check 4 way valve proper operation (if present)					X		
Check 3 way valve proper operation (if present)					X		
Check presence of air the hydraulic circuit		X					
Check the color of the humidity display on the liquid line				X			
Check if there are any freon leaks ⁽²⁾							X



⁽¹⁾ If the unit is installed in strongly windy areas, near coasts or deserts or in areas subjects to wind and/or sand storms, or near airports, industries or in places with high levels of air pollution in general inspect the unit more frequently (every three months) to check the real condition of the surface protection. follow the instructions given in the paragraph "Cleaning the microchannel condensing coils".



⁽²⁾ In order to carry out operations on the refrigerant, it is necessary to observe the European Regulation 517_2014, "Obligations regarding the containment, use, recovery and destruction of fluorinated greenhouse gases used in stationary refrigeration, air conditioning and heat pump equipment".



⁽³⁾ It can be carried out with a higher frequency (also weekly) depending on the Δt .

7.4.3 Compressor

Actions	Frequency						
	Daily	Monthly	Every 2 months	Every 6 months	Once a year	Every 5 years	If required
Visually inspect compressors		X					
Check compressor noise and vibration		X					
Check compressors supply voltage				X			
Check the compressors electrical connections					X		
Check the oil level in the compressors using the oil level indicator light.				X			
Check that the crankcase heaters are powered and working properly.		X					
Check the conditions of the compressors electrical cables and their connection to their clamps				X			



Monthly and daily procedure can be directly done by the Owner. The other interventions must be done by qualified and suitably trained personnel.



Do not start any cleaning operation before disconnecting the unit from the electrical power supply, turning the main switch to OFF Position. Do not touch the equipment with barefoot or wet /damp parts of the body.



Any intervention on the cooling circuit must be done by qualified and suitable trained technicians, licensed in compliance with current local laws and regulation.

7.4.5 Check and calibration of the refrigerant leak detector

The maintenance (sight, operational and system one) of the detector must be done once a year to keep unchanged its safety and measurement performance and to grant the refrigerant detection alarm. The maintenance must be carefully done by skilled and qualified personnel. The system control, carried out by qualified personnel, must be done every 12 months at least and involves minimum the following operations:

- Functional check
- Failure relay check
- Alarm relay check
- Point 0 check

Control and calibration check with test gas; to carry on such a test, you can buy the calibration kit or send the detector to the Manufacturer for the calibration.

To carry on the test, you need to use the dedicated kit by the Manufacturer; In any case refer to the handbook of the detector supplied with the unit.

The procedure indicated by the Manufacturer must be strictly followed. If the test is successfully completed, the detector can be installed and use once more.

If after the calibration is sensibility fall below the 55%, the detector must be replaced as suggested by the manufacturer.

7.4.6 End of seasons

If the unit is to be left out of commission for a long period, the hydraulic circuit should be drained down. This operation is compulsory if the ambient temperature is expected to drop below the freezing point of the fluid in the circuit (typical seasonal operation).

Before a new filling, the system must be washed.

7.4.7 Unit OFF

To stop the unit, press the ON/OFF key on the microprocessor, turning it on OFF position. If the unit will be OFF for more than 24 h turn the main switch to OFF position to cut the unit electrical power.

If any malfunction has occurred during the unit operation, solve it asap, in order to avoid that it will occur again at next operation.

7.5 Refrigerant circuit repair



Before any intervention with devices able to create sparks, heat, naked flames etc. totally empty and blow the circuit from any refrigerant.

For leak detection, the system should be charged with nitrogen using a gas bottle with a pressure reducing valve, until 15 bar pressure is reached. Any leakage is detected using a bubble leak finder. If bubbles appear discharge the nitrogen from the circuit before brazing using the proper alloys.



Never use oxygen instead of nitrogen: explosions may occur.

Site assembled refrigerant circuits must be assembled and maintained carefully, in order to prevent malfunctions.

Therefore:

- Avoid oil replenishment with products that are different from that specified and that are pre-loaded into the compressor.
- In the event of a gas leakage on machines using refrigerant R407C, even if it is only a partial leak, do not top up. The entire charge must be recovered, the leak repaired and a new refrigerant charge weighed in to the circuit.
- When replacing any part of the refrigerant circuit, do not leave it exposed for more than 15 minutes.
- It is important when replacing a compressor that the task be completed within the time specified above after removing the rubber sealing caps.
- When replacing the compressor following a burn out, it is advisable to wash the cooling system with appropriate products including a filter for acid.
- When under vacuum do not switch on the compressor.

8. DECOMMISSIONING

8.1 Disconnect the unit



All decommissioning operations must be performed by authorized personnel in accordance with the national legislation in force in the country where the unit is located.

- Avoid spills or leaks into the environment.
- Before disconnecting the machine please recover:
 - the refrigerant gas;
 - Glycol mixture in the hydraulic circuit;
 - the compressor lubricating oil.

Before decommissioning the machine can be stored outdoors, providing that it has the electrical box, refrigerant circuit and hydraulic circuit intact and closed.

8.2 Disposal, recovery and recycling

The frame and components, if unusable, should be taken apart and sorted by type, especially copper and aluminum that are present in large quantities in the machine.

All materials must be recovered or disposed in accordance with national regulations.



The refrigerant circuit of the unit contains lubricant oil that binds the disposal mode of components .

8.3 RAEE Directive (only UE)



The crossed-out bin symbol on the label indicates that the product complies with regulations on waste electrical and electronic equipment.
The abandonment of the equipment in the environment or its illegal disposal is punishable by law.

This product is included in the application of Directive 2012/19/EU on the management of waste electrical and electronic equipment (WEEE).

The unit should not be treated with household waste as it is made of different materials that can be recycled at the appropriate facilities. Inform through the municipal authority about the location of the ecological platforms that can receive the product for disposal and its subsequent proper recycling.

The product is not potentially dangerous for human health and the environment, as it does not contain dangerous substances as per Directive 2011/65/EU (RoHS), but if abandoned in the environment it has a negative impact on the ecosystem.

Read the instructions carefully before using the unit for the first time. It is recommended not to use the product for any purpose other than that for which it was designed, as there is a risk of electric shock if used improperly.

9. DIAGNOSIS AND TROUBLESHOOTING

9.1 Fault finding

All units are checked and tested at the factory before shipment, however, during operation an anomaly or failure can occur.



BE SURE TO RESET AN ALARM ONLY AFTER YOU HAVE REMOVED THE CAUSE OF THE FAULT; REPEATED RESET MAY RESULT IN IRREVOCABLE DAMAGE TO THE UNIT.

Code	Alarm Description	Cause	Solution
P1	Alarm Sensor PB1	Wrong electrical connections. Sensor defect.	Check the electrical connection of the sensor to the terminal board, if correct call the service to replace the sensor.
P2	Alarm Sensor PB2		
P3	Alarm Sensor PB3		
P4	Alarm Sensor PB4		
A01	High pressure switch alarm.	In heating mode: Insufficient user circuit water flow; In heating mode: Insufficient air flow at the source fan.	Restore the correct circuit water flow. Restore the correct air flow at the source fan.
A02	Low pressure switch alarm.	Refrigerant charge leakage.	Find leakage and repair.
A05	High pressure alarm.	Transducer defect.	Replace the faulty transducer.
A06	Low pressure alarm.	Refrigerant charge leakage.	Find leakage and repair.
A07	Anti-freeze alarm from analog input.	Too low water temperature.	Check user temperature set point. Check user water flow.
A08	Source heat exchanger flow switch alarm. (air/water water/water unit)	Presence of air or dirtiness in the user hydraulic system.	Bleed carefully the user hydraulic system or check and clean the water service.
A09	Compressor 1 overload.	Compressor input current outside operation limits.	Contact the Company.
A10	Compressor 2 overload.		
A11	Overload source fan alarm.	Fan input current outside operation limits.	Check the proper operation of the source fan and, in case, replace it.
A12	Error alarm in defrosting.	Defrost time too long. Outside temperature outside the working limits. Refrigerant charge leakage.	Check defrost set point. Restore normal working conditions. Find leakage and repair.
EE	EEPROM Alarm	Severe hardware damage in the microprocessor control system.	Switch the unit OFF and, after few seconds switch the unit ON; if the alarm appears again contact the service.

10. DIMENSIONAL DRAWING



Dimensional drawings are to be considered indicative and not binding, therefore it is always necessary to request the definitive dimensional drawing before setting up the installation of the unit.

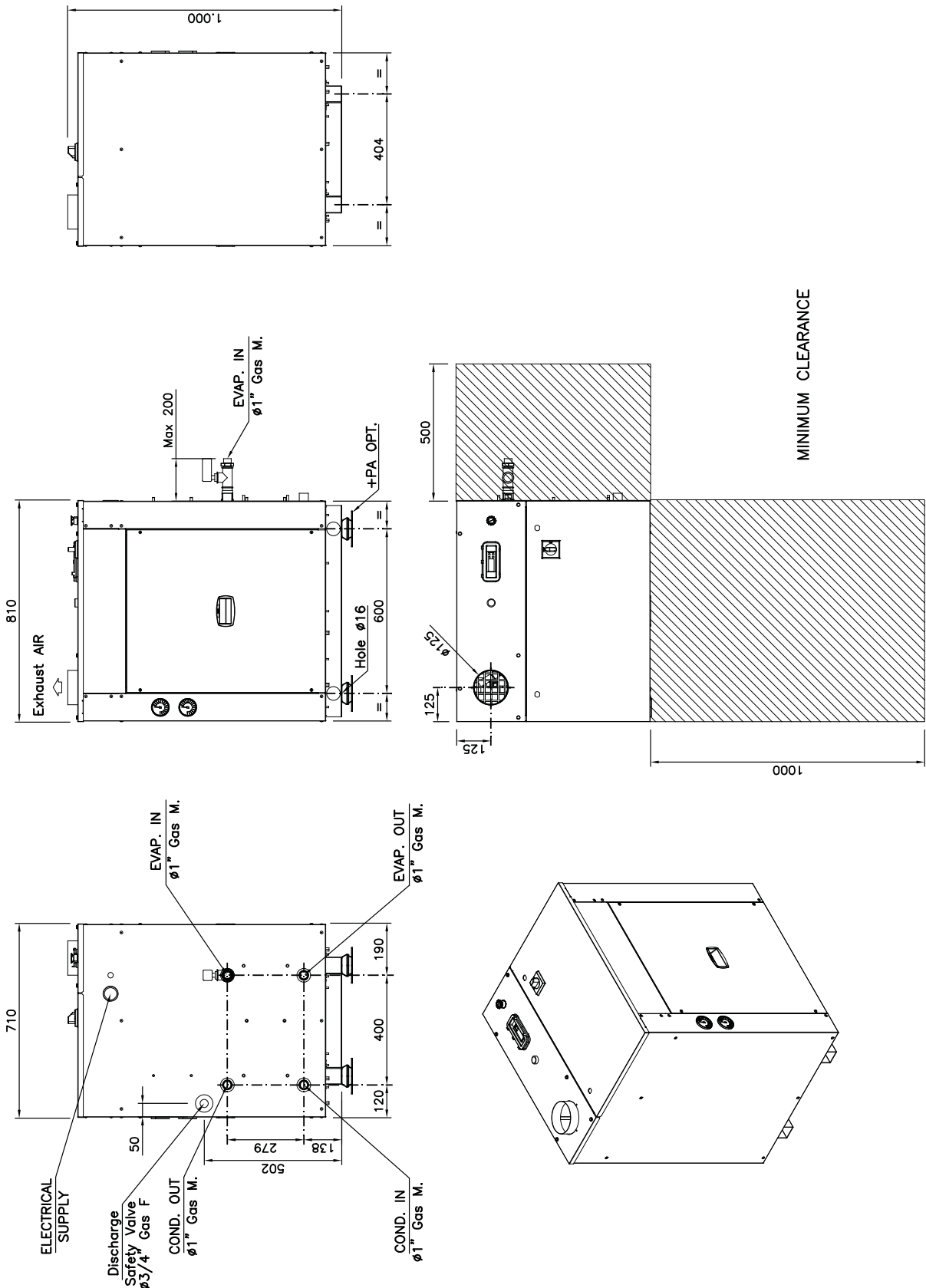



EMICON AC SPA

Via A. Volta, 49 ▪ cap 47014 ▪ Meldola (FC)
Tel. +39 0543 495611 ▪ Fax +39 0543 495612
emicon@emiconac.it ▪ www.emiconac.it

P.IVA e C.F 03402390409 ▪ R.E.A. 299199

Technical data shown in this booklet are not binding.

The Company shall have the right to introduce at any time whatever modifications necessary to the improvement of the product.
The reference languages for the whole documentation are Italian and English. The other languages are to be considered only as guidelines.
